

50 CUBIC FOOT ALTERNATING WATER SOFTENER (ASME)

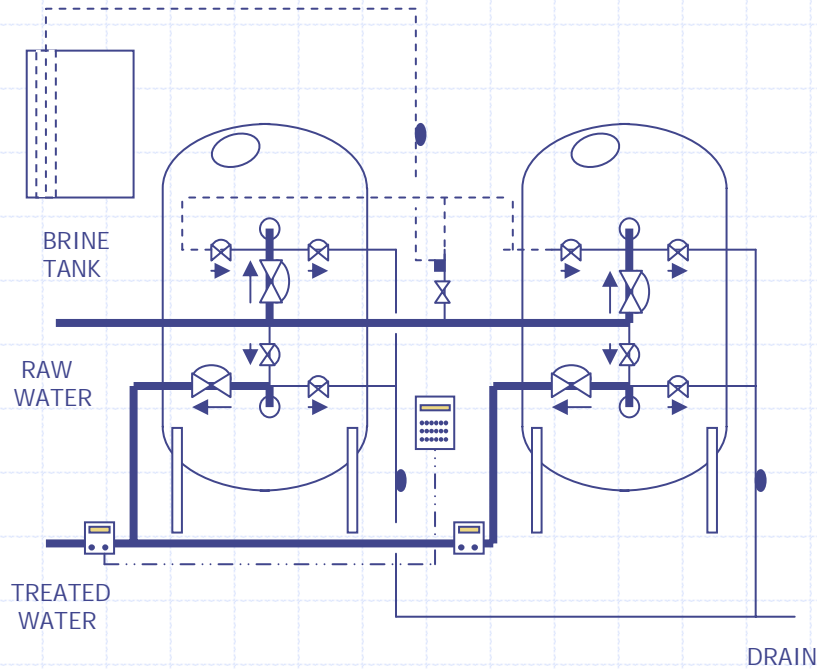

STEEL TANKS (ASME)
AQUAMATIC STAGER CONTROLLER
CENTRAL BRINE TANK
50 CUBIC FEET RESIN IN EACH TANK



DWC1500AM962ALT

ALTERNATING TWIN 50 CUFT COMMERCIAL WATER SOFTENER

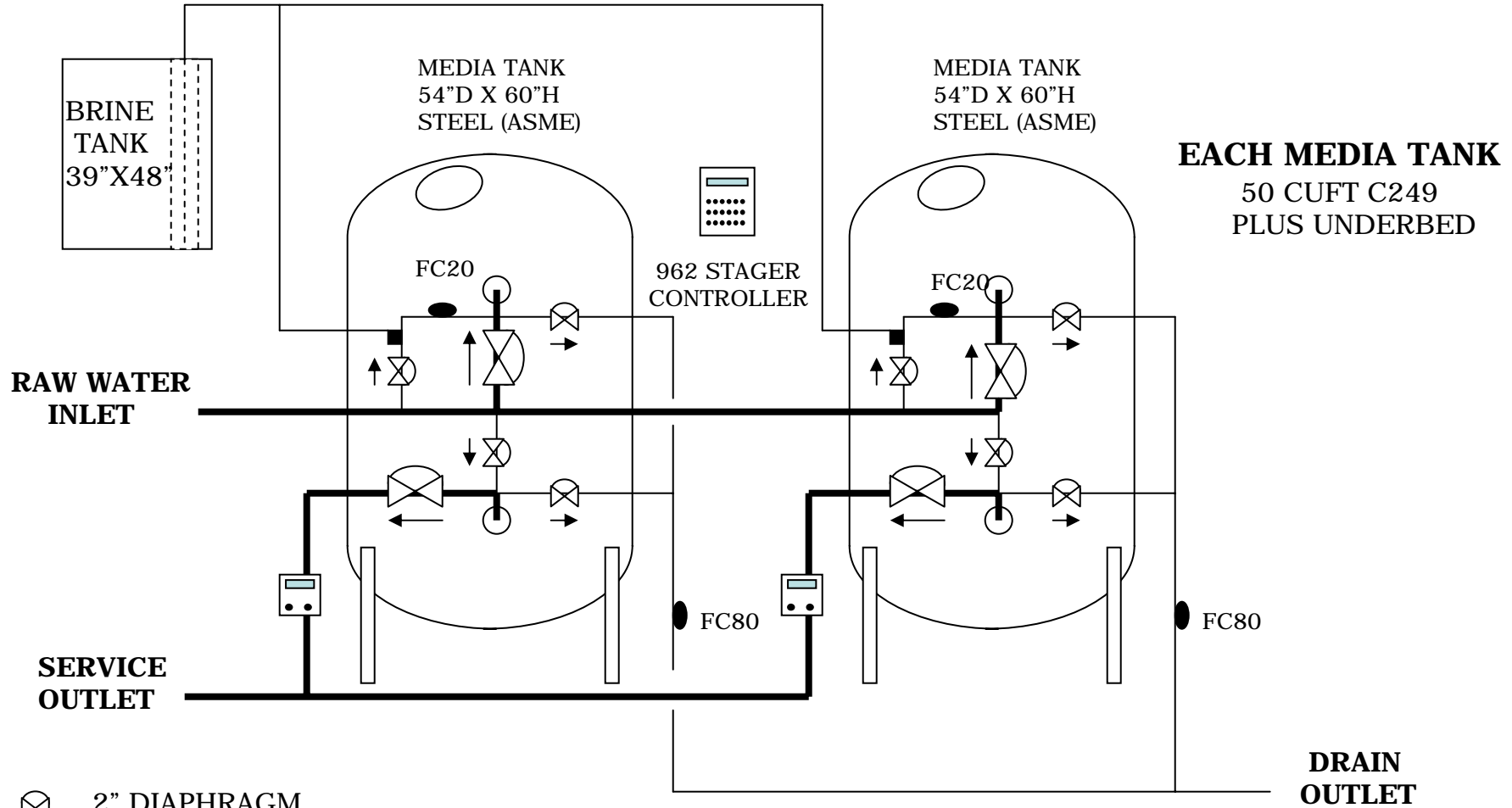



EACH MEDIA TANK
 50 CUFT C249
 PLUS UNDERBED

 2" DIAPHRAGM

 4" DIAPHRAGM

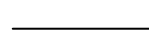
 SIGNET FLOW MONITOR

 2" GALVANIZED

 4" GALVANIZED

DUFF COMPANY	
DWC1500AM962ALT	
LRZ	17 JUL 2002