

COMMERCIAL WATER SOFTENER MODEL DWC750S72

**SERVICE
OUTLET**

**SERVICE
INLET**

**REMOTE
METER**

SPECIFICATION

50 GPM FLOW
80 GPG HARDNESS
72K GPD TOTAL

SYSTEM SEVEN

-ONE TANKS IN
SERVICE, ALWAYS

-ONE TANK IN
REGEN/STAND BY

PERFORMANCE

REGEN PER 9300 GAL
OR EVERY 3 HOURS

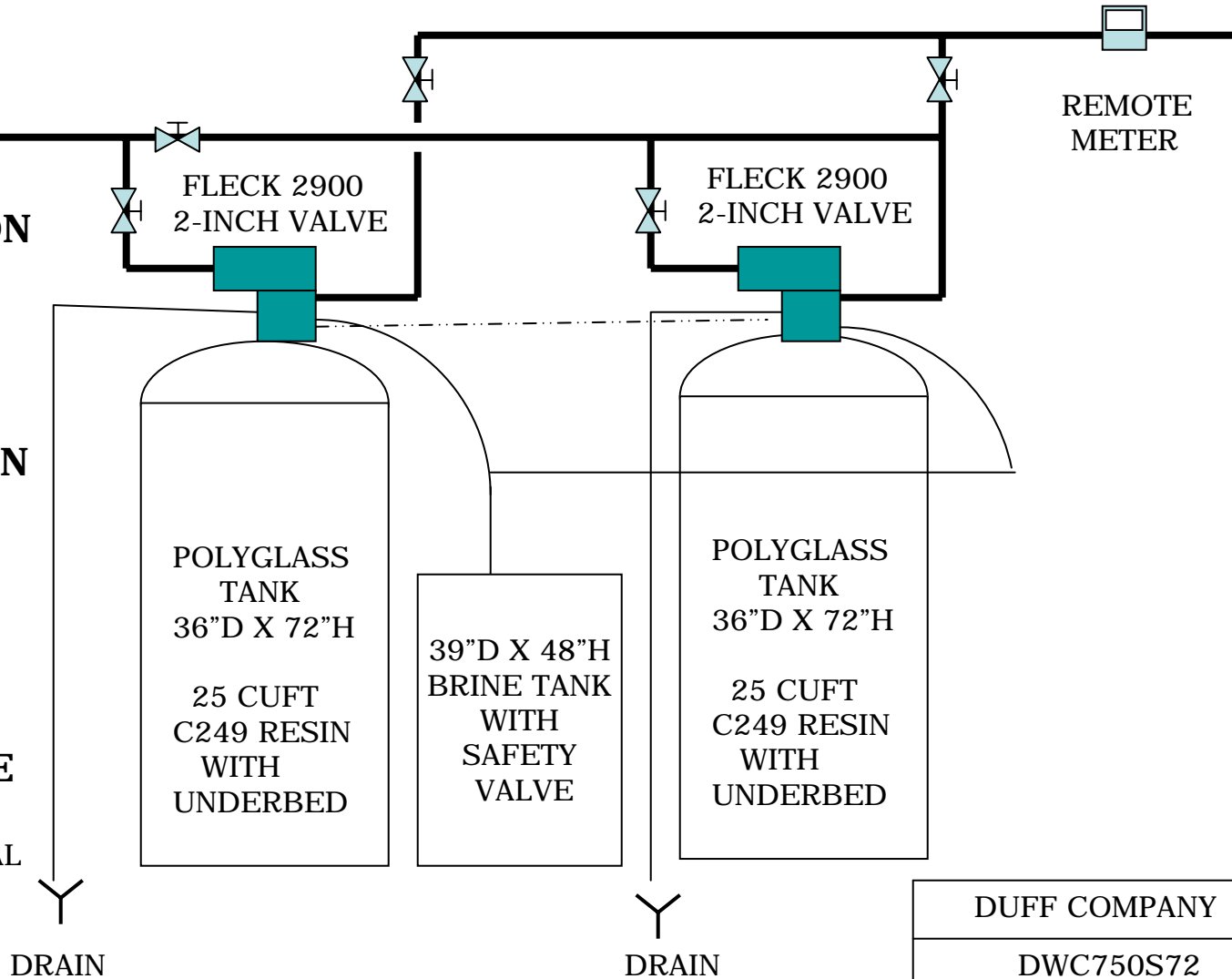

DRAIN

DRAIN

SYSTEM SEVEN OPERATION, 1,500,000 GRAIN

DUFF COMPANY	
DWC750S72	
27 JUNE, 02	LRZ